

This manual contains important warnings and information. READ AND KEEP FOR REFERENCE.

LIQUIDYNAMICS Hose Reel

Instruction & Parts Manual

Large Capacity Spring Rewind Hose Reel Model 88501-100L



! WARNING

This symbol indicates a potentially hazardous situation which, if not avoided, could result in death or serious injury.

Introduction:

These hose reels are a practical, safe, reliable and economical way to extend the useful life of hoses, maintain a safe and clean environment and significantly improve Service Technician efficiency. Typical applications are for use with air, engine and gear oils, hydraulic and transmission fluids and antifreeze.

! WARNING

Use these reels only for the purpose for which they have been designed. Do not exceed working pressure of reel or hose. Do not use these reels for flammable, explosive or corrosive applications. Do not modify any components and use only original spare parts.

! CAUTION

Insure that incoming line pressure does not exceed rated operating pressure of your model hose reel. Refer to technical specifications on page 5 for pressure ratings.

! CAUTION

To avoid damage to the reel, control handle or meter, always hold onto hose while it is rewinding.

Before Installation:

1. Make sure mounting surface is sturdy enough to hold the weight of the hose reel and take the stress of use. If wall mounting, check both the inside and outside of wall to make sure no electrical or plumbing lines will interfere with installation.
2. It is recommended to install a supply line shut-off valve just before the connection hose between product supply line and reel, fig. 1. This allows easy maintenance of reel, hose and control valve or meter.

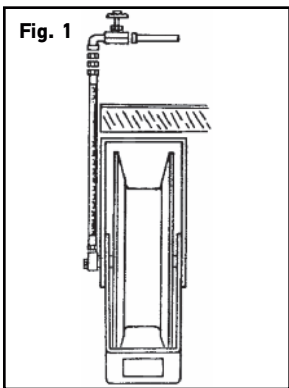

3. Product service labels (fig. 2) are available for ease of installation. Consult your Liquidynamics catalog or call 800-894-3572 for specific recommendations and part numbers.

! CAUTION

This symbol indicates a potentially hazardous situation which, if not avoided, may result in injury or damage to equipment.

4. Flush product supply lines with generous quantities of product in order to remove air, loose dirt, scale, shavings, etc. This will prevent damage to reels, meters and control valves.

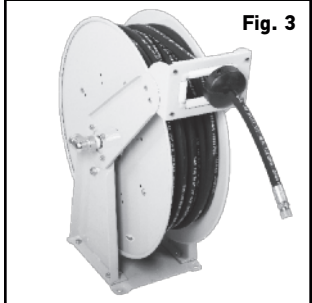

5. Determine desired orientation of reel to best fit your specific installation. Reels are shipped with guide arm in position shown in fig. 3.

Note:

Hose spools off from reel in a clockwise direction when viewed from swivel side of reel, (fig. 4).

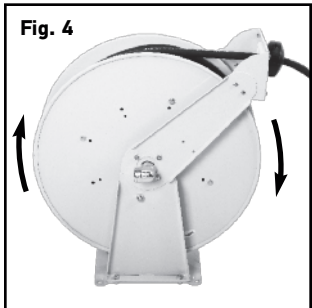

Possible Hose Guide Configurations

Reels may be mounted on ceiling, wall or tank (floor) as shown in fig. 5a, 5b and 5c. Refer to instructions that follow to reposition guide arm.



Fig. 5a Tank, floor or wall mount, as supplied by Liquidynamics.



Fig. 5b Alternate wall mount.

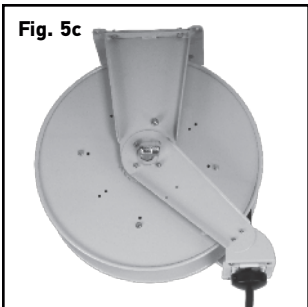

Fig. 5c Ceiling mount.

Hose Guide Re-Orientation

Depending on the location of reel installation, it may be necessary or desirable to change the orientation of the hose guide arm, fig. 6. This is easily accomplished without release of spring tension. Possible guide arm orientations are shown in fig. 5, where 5a is the “normal” position as supplied by Liquidynamics.

Fig. 5a; used for wall, floor and tank mounting
 Fig. 5b; used for wall, floor and tank mounting
 Fig. 5c; used for ceiling or wall mount

1. Pull hose from reel until latch key is engaged to prevent hose retraction.

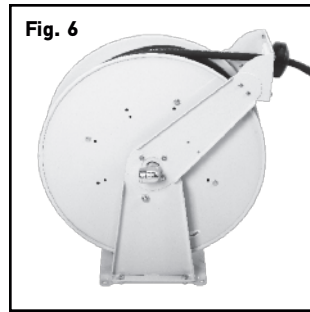

2. Remove ball stop by removing 2 ea. Allen head screws, fig. 7.

Re-position guide arm as shown in fig. 5 as follows:

1. For position 5b and 5c
 - a.) Remove 4 ea. nuts and bolts on each side of guide arm, fig. 8.
 - b.) Rotate guide arm to 90° to position shown in fig. 5b.
 - c.) Reinstall 8 ea. nuts and bolts securely.
 - d.) Reinstall ball stop at desired location on hose.

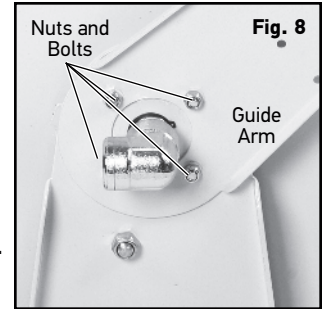
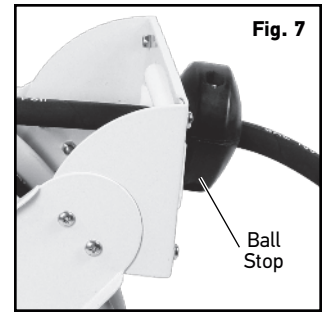

Technical Specifications:

Model	Working Pressure	Hose Dia. ID	Hose Length	Inlet Connection	Outlet Connection	Max Winding Capacity	Connecting Hose Length	Shipping Weight
88501-100L	870 PSI	—	—	3/4" NPTF	3/4" NPTF	3/4 x 50'	—	62 lb

Model 88402, 88402DEF and 88403 Series Reels

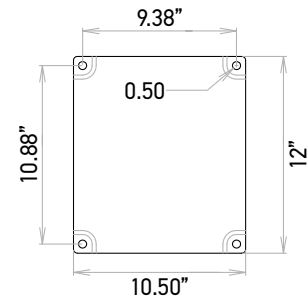
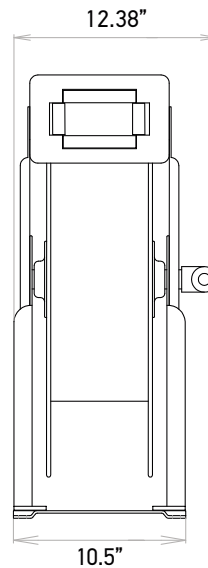
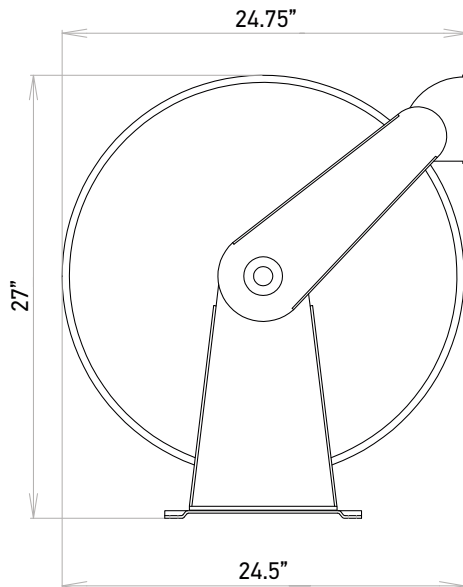

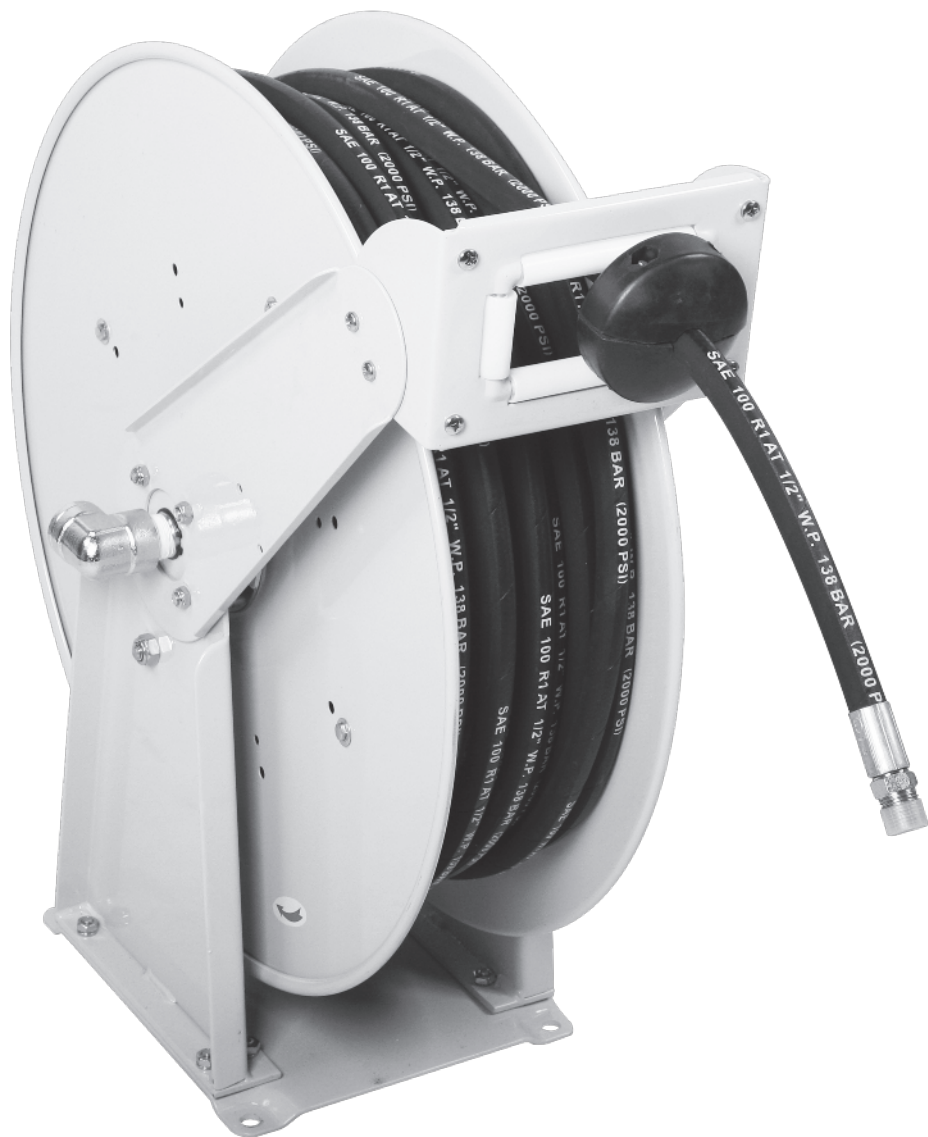

1.	S45201	Hose Guide Kit, 88402, 88403 Reels
2.	S45202	Hose Guide Kit, 88405 Reel
3.	S45203	Hose Stop, 3/4" Hose
4.	S45204	Hose Stop, 1" Hose
5.	S45205	Seal Kit for 88402, 88403 and 88405 Reels
5A.	S45205DEF	Seal Kit for 88402DEF Reels
6.	S45206	Internal Swivel for 88402, 88403 and 88405 Reels
7.	S45207	1" Inlet Swivel for 88402, 88403 and 88405 Reels
7A.	S45207DEF	3/4" Swivel Inlet assembly for 88402DEF Reels
8.	S45208	Retaining Ring Clip for 88402, 88403 and 88405 Reels
9.	S45209	Pawl Kit, Includes pawl, stem and spring (88402,88403 and 88405 Reels)



LIQUID DYNAMICS™

2311 S. Edwards • Wichita, KS 67213 / TEL: 316-943-5477 • FAX: 316-943-4760 / TOLL FREE: 800-894-3572
 E-MAIL: productinfo@liquidynamics.com / WEBSITE: www.liquidynamics.com